

01 - 02.3

10.05.GB

**LDM shut-off valves
with hand wheel**





UV 226 (Ex) UV 236 (Ex)

Shut-off valves DN 15 to 400, PN 16, 25 and 40 with hand wheel

Description

Shut-off valves series UV 2x6 are hand-wheel valves that excel with unique features suitable for a long-time no maintenance service. If bellows is used, it ensures a hermetic tightness to environment and in addition it is added with a safety packing made of graphite. Valves with graphite packing are equipped with pack saet. The most advantageous feature is low linear forces when opening or closing the valve which does not change during the life-time. Thanks to a yoke design, the valve can be easily insulated and its hand wheel can be operated even at high temperatures of process medium. The hand wheel is non-rising which enables the valves application in unaccess-ible places. The visible indicator ensures an easy identification of the valve position. The valves UV 2x6 acc. to ČSN EN 13709 (10/2003). The valves UV 2x6 Ex meet the requirements II 1/2G IIB acc. to ČSN-EN 13 463-1.

Application

The valves are especially designed for applications in warm-water and steam circuits in power plants, heating plants, heat

exchange stations, heat transferring stations and common heating applications. Thanks to a great scale of available valve sizes, the valve is suitable for a tight closing (shutting down) of main branches, by-passes, extracting and sampling pipelines. The used materials enable the valves to be installed also in air-conditioning, refrigerating and other special applications.

Process media

The valves UV 2x6 are suitable for shutting off water, water vapour and other liquids and gases which are compatible with used materials of the valve body and internal materials. The valves UV 2x6 (Ex) can be also used for industrial and heating gases and flammable liquids.

Installation

The valves can be installed in any position but it is recommended to ensure enough space for hand wheel operating. The flow direction is indicated by the arrows on the valve body. The alternate flow direction through the valve is permissible.

Technical data

Series	UV 226 (Ex)	UV 236 (Ex)
Execution	Shut-off valve, straight-through	
Nominal size range	DN 15 to 400	
Nominal pressure	PN 16, 25 and 40	
Body material	Cast steel 1.0619 (GP240GH)	Stainless steel 1.4581 (GX5CrNiMoNb19-11-12)
Plug material (DIN W.Nr. / ČSN)	1.4021 / 17 022.6	1.4571 / 17 348.4
Operating temperature range	-20 to +400°C	
Connection	Type B1 (raised-faced flange) acc. to ČSN-EN 1092-1 (4/2002) Face to face dimensions comply with ČSN EN 558-1 (3/1997), section 1	
Type of plug	Disc; pressure-balanced plug with pilot system	
Flow characteristic	On-Off	
Leakage rate	Acc. to ČSN EN 12266-1 (11/2003) - leakage rate class A	
Packing	Bellows with safety graphite packing or graphite packing	

Max. permissible operation pressures

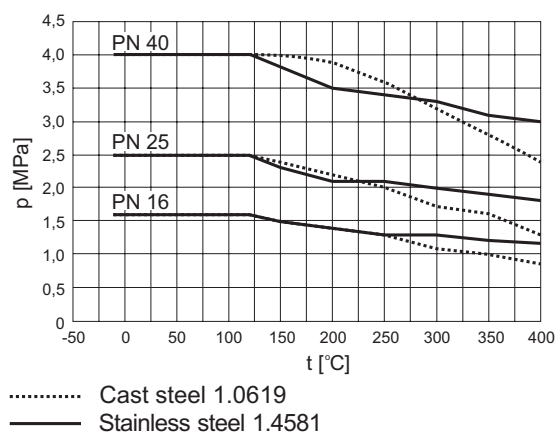

Values of Kvs, differential pressure and pressure loss coefficient ζ (zeta)

DN	Kvs [m ³ /hod]	ζ	Δp_{max} [MPa]
15	4.3	4.5	4.00
20	7.0	5.2	4.00
25	11.0	5.2	4.00
32	17.5	5.5	4.00
40	27.0	5.6	4.00
50	47.0	4.5	4.00
65	68.0	6.2	4.00
80	116.0	4.9	4.00
100	162.0	6.1	4.00
125	250.0	6.2	4.00
150 UV 2x6 R,S	364.0	6.1	2.00
150 UV 2x6 B,V	364.0	6.1	4.00
200	570.0	7.9	4.00
250	800.0	9.8	4.00
300	1100.0	10.7	4.00
400	1700.0	14.2	4.00

Valve complete specification No. for ordering UV 2x6 (Ex)

		XX	XXX	XXX	XX	/	XXX	-	XXX	XX
1. Valve	Shut-off valve	UV								
2. Series	Bellows sealed globe valves made of cast steel 1.0619		226							
	Bellows sealed globe valve made of stainless steel 1.4581		236							
3. Type of actuating/packing <small>¹⁾ For DN 15 to 150 only ²⁾ For DN 150 to 200 only ³⁾ For DN 150 to 400 only</small>	Hand wheel / bellows with safety graphite packing ¹⁾			R						
	Hand wheel / graphite packing ¹⁾			S						
	Pressure balanced plug / bellows with safety graphite packing ²⁾			V						
	Pressure balanced plug / graphite packing ³⁾			B						
4. Connection	Flanges with raised faces acc. to DIN standard (see note)				1					
5. Body / bonnet material <small>⁴⁾ For R and V execution only</small>	Cast steel 1.0619 / Cast steel 1.0619					1				
	Stainless steel 1.4581 / Cast steel 1.0619 ⁴⁾					3				
	Stainless steel 1.4581 / Stainless steel 1.4581					8				
	Other material on request (e.g.: WN 1.7357, nickel alloys, etc.)					9				
6. Nominal pressure	PN 16							16		
	PN 25							25		
	PN 40							40		
7. Max. operating temp. °C	400°C							400		
8. Nominal size	DN 15 to 400								XXX	
9. Execution	Normal									
	Non - explosive									Ex

Ordering example: UV 226 R11 40/400-50

Note: Other connection (female face, plain face, etc.) possible on special request.

Dimensions and weights for the type UV 2x6 (Ex)

DN	PN 16						PN 25						PN 40																								
	D ₁	D ₂	D ₃	d	n	a	D ₁	D ₂	D ₃	d	n	a	D ₁	D ₂	D ₃	d	n	a																			
	mm	mm	mm	mm		mm	mm	mm	mm	mm		mm	mm	mm	mm	mm		mm																			
15	95	65	45	14	4	16	As for PN 40						95	65	45	14	4	16																			
20	105	75	58			18							18	18	18			18	18	18	18	18	18	18	18	18	18										
25	115	85	68			18							18	18	18			18	18	18	18	18	18	18	18	18	18										
32	140	100	78			18							18	18	18			18	18	18	18	18	18	18	18	18	18										
40	150	110	88	18	4 ¹⁾	20							18	18	18	18	18	18	165	125	102	18	8	20													
50	165	125	102			22																		22	22	22	22	22	22	22	22	22	22	22	22	22	
65	185	145	122			24																		24	24	24	24	24	24	24	24	24	24	24	24	24	24
80	200	160	138			24																		24	24	24	24	24	24	24	24	24	24	24	24	24	24
100	220	180	158	22	8	26							26	26	26	26	26	26	235	190	162	22	8	26													
125	250	210	188			28																		28	28	28	28	28	28	28	28	28	28	28	28	28	
150 ^{R, S, B)}	285	240	212			28																		28	28	28	28	28	28	28	28	300	250	218	26	8	28
150 ^{V)}	285	240	212			28																		28	28	28	28	28	28	28	28	300	250	218	26	8	28
200	340	295	268	26	12	24							360	310	278	26	12	30	375	320	285	30	12	34													
250	405	355	320			26							425	370	335	30		32	450	385	345	33		38													
300	460	410	378			28							485	430	395	30		34	515	450	410	33		42													
400	580	525	490			30							620	550	505	36		40	660	585	535	39		50													

DN	PN 16, PN 25, PN 40					
	H	L	V	K	f	m
	mm	mm	mm	mm	mm	kg
15	6	130	189	120	2	4.3
20	6	150	189	120		5.1
25	6	160	189	120	3	5.8
32	10	180	220	160		9.5
40	10	200	220	160	3	9.8
50	16.5	230	295	195		17.5
65	16.5	290	295	195	3	20.5
80	25	310	368	280		34
100	25	350	368	280	2	44
125	40	400	523	350		77
150 ^{R, S, B)}	40	480	523	350	2	110
150 ^{V)}	40	480	558	350		113
200	50	600	505	350	2	240
250	75	730	663	350		410
300	75	850	713	350	2	610
400	100	1100	855	350		1240

¹⁾ regarding the previous standards in force, we can optionally make an execution with No. of connection bolts corresponding to CSN-EN 1092-1

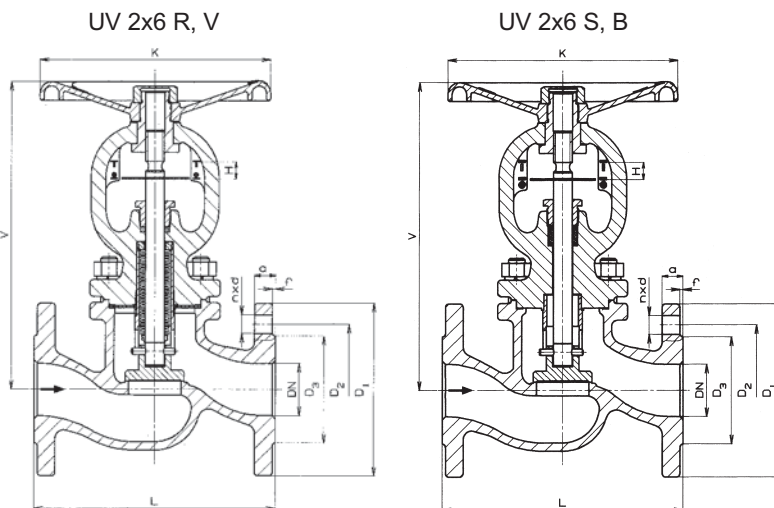



LDM, spol. s r.o.
Litomyšlská 1378
560 02 Česká Třebová
Czech Republic

tel.: +420 465 502 511
fax: +420 465 533 101
E-mail: sale@ldm.cz
<http://www.ldm.cz>

LDM, spol. s r.o.
Office in Prague
Tiskařská 10
108 28 Praha 10 - Malešice
Czech Republic

tel.: +420 234 054 190
fax: +420 234 054 189

LDM, spol. s r.o.
Office in Ústí nad Labem
Mezní 4
400 11 Ústí nad Labem
Czech Republic

tel.: +420 475 650 260
fax: +420 475 650 263

LDM servis, spol. s r.o.
Litomyšlská 1378
560 02 Česká Třebová
Czech Republic

tel.: +420 465 502 411-3
fax: +420 465 531 010
E-mail: servis@ldm.cz

LDM, Polska Sp. z o.o.
Modelarska 12
40 142 Katowice
Poland

tel.: +48 32 730 56 33
fax: +48 32 730 52 33
mobile: +48 601 354999
E-mail:
ldmpolska@poczta.onet.pl

LDM Bratislava s.r.o.
Mierová 151
821 05 Bratislava
Slovakia

tel.: +421 2 43415027-8
fax: +421 2 43415029
E-mail: ldm@ldm.sk
<http://www.ldm.sk>

LDM - Bulgaria - OOD
z. k. Mladost 1
bl. 42, floor 12, app. 57
1784 Sofia
Bulgaria

tel.: +359 2 9746311
fax: +359 2 9746311
GSM: +359 88 925766
E-mail: ldm.bg@mbox.cit.bg

OAO "LDM"
F. Engels str. 32/1
105005 Moscow
Russia

tel.: +7 095 7973037
fax: +7 095 7973037
E-mail: inforus@ldmvalves.com

LDM Armaturen GmbH
Wupperweg 21
D-51789 Lindlar
Germany

tel.: +49 2266 440333
fax: +49 2266 440372
mobile: +49 177 2960469
E-mail: ldmarmaturen@ldmvalves.com
<http://www.ldmvalves.com>

Your partner