

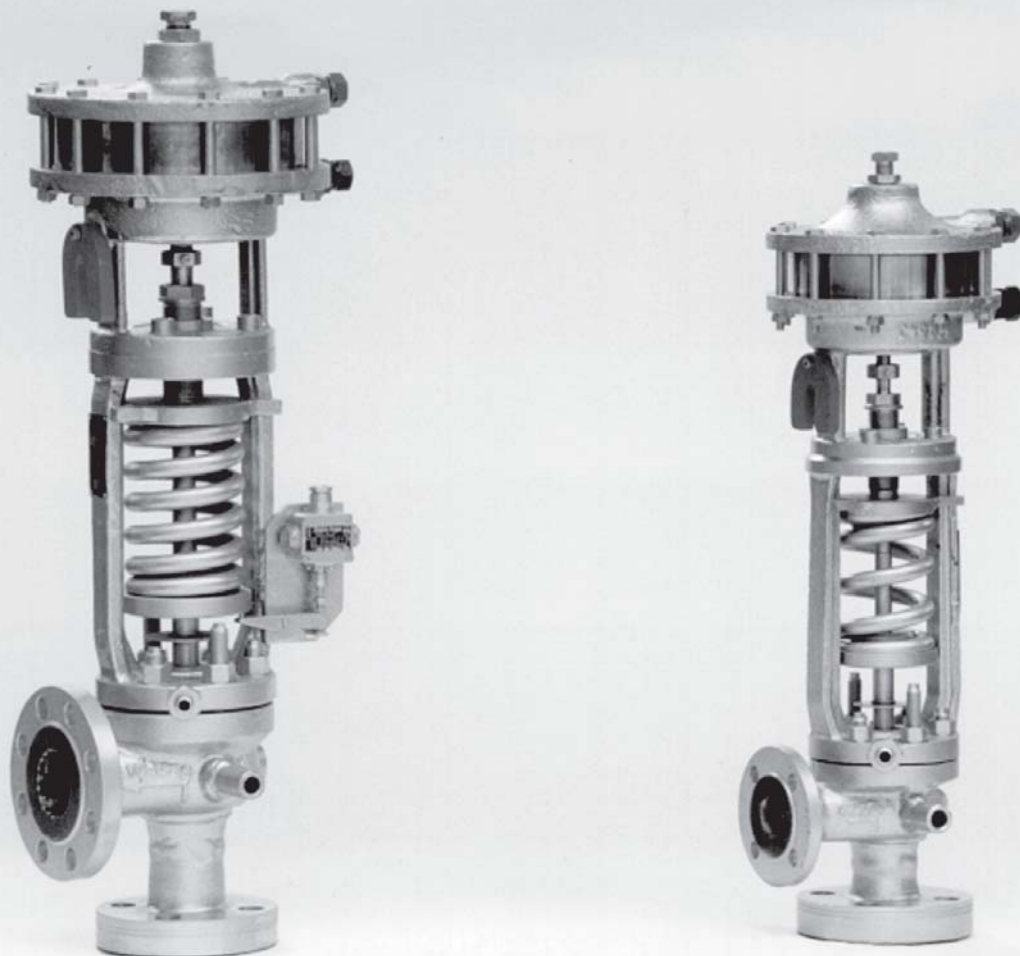

02 - 07.1
01.22.GB

FULL-LIFT SAFETY VALVES WITH ADDITIONAL LOADING

SiZ 1508





SiZ 1508

Full-lift safety valves with additional loading

DN 25 x 40 - 350 x 600

The full-lift safety valve with additional loading is a valve designed for automatic protection of a pressure equipment

(steam boilers, pressure pipelines, steam-conditioning stations, pressure vessels, turbine extraction etc.) against unpermitted pressure increase over allowable limit. Certificate of the valve construction and guaranteed output of the safety valves type SiZ 1508 was issued by Český úřad bezpečnosti práce (The Czech Institute for Safety Work) in Prague, under ref. No. 1699/0.50/69 dated 24th of September 1969. From that moment the valves type SiZ 1508 were involved into the approved equipment of steam boilers according to ČSN 07 0620. The valve output guaranteed in accompanying documents is guaranteed only provided that the pressure loss in pipeline does not exceed 3% of opening pressure in inlet pipeline and 25% in outlet pipeline. The safety valves SiZ 1508 are designed for water vapour, air, and non-aggressive gases and vapours. The highest temperature of securing medium is up to 600 °C. The valves can operate continuously in dust environment with ambient temperature to 80 °C. After consulting the producer, it is possible to pipe the valve in environment with ambient temperature below zero. The opening pressure range is specified in the "Technical data" table.

The valves are delivered and must be operated together with their accessories, i.e. control unit and aerating system. Single parts can be delivered only in case of the replacement for previously delivered equipment.

Technical data

Valve size DN	Seat values		Opening pressure		Certified flow coefficient $K_{dr} [-]$
	d [mm]	A [mm ²]	p_{set} [barg] minimal	p_{set} [barg] maximal	
25 x 40	16	201	32	400	0,86
40 x 65	25	491	24	275	
	28	616	24	225	
50 x 80	32	804	24	235	0,84
	36	1018	24	195	
65 x 100	40	1257	16	180	
	46	1662	16	150	
80 x 125	50	1964	16	135	
	56	2463	16	110	
100 x 150	63	3117	16	100	
	70	3848	16	86	
125 x 200	77	4657	12	80	
	85	5675	12	70	
150 x 250	93	6793	10	60	
	98	7543	10	50	
175 x 300	110	9503	10	42	
	117	10750	10	38	
200 x 350	125	12270	6	32	
	140	15390	6	26	
250 x 400	155	18870	6	22	
	168	22170	6	18	
300 x 500	180	25450	4	16	
	200	31420	4	13	
350 x 600	220	38010	3	11	0,83
	235	43370	3	10	

A - flow seat section in mm² | d - seat inner diameter in mm

Description

Body is angle, with possibility of either flanges on both ports, or weld ends or combined. Inlet port is of a nozzle type, outlet port is extended. There are welded lugs on the valve body for gripping the valve to the load-bearing structure and absorbing reaction forces. Plug, equipped with an additional flat for achieving of stronger lifting force, is pressed by the means of the spring and pressure air cylinder to the seat. There is a double differential piston moving inside of pressure air cylinder to which the lifting and loading airs are supplied through the hoses from the control unit. The valve is set and adjusted by its producer to the opening pressure specified in the customer's order. Such a setting is secured against an unallowable interference. Dimensions of connection flanges and weld ends are specified after the agreement between the producer and customer when the order is being technically cleared. Standard weld ends correspond to ČSN 13 1075 (3/1991), standard flanges correspond to ČSN EN1092-1+A1 (7/2013) possibly ČSN13 1060. The valves SiZ 1508 correspond to ČSN

Valve function

The safety valve is controlled by its control unit. If the control unit is for any reason put out of service, the valve may be shortly operated just exceptionally or in case of emergency (pressure air supply failure, control unit breakdown etc.). Any longer operation or repeated service in such state may lead to a rapid reduction of the valve service life due to vibrations and leakage.

After reaching the opening pressure value, control unit lets the air out of the space above the piston of pressure air cylinder (loading air) Air pressure from below the plug (lifting air) plus securing medium pressure acting on the plug overcome spring force and safety valve then rapidly opens to its full lift. When the pressure drops, then whole action runs reversed. Rapid opening and closing are just two main preferences of the valves. The valve reaches full opening after the pressure of securing medium increases by max. 3% above the value of set opening pressure (p_{set}). The valve becomes tight closed after the pressure of securing medium drops by max. 5% below the value of set opening pressure (p_{set}).

In case of control air pressure supply failure, the force is induced by the securing medium pressure only. The valve opening runs incomparably more slowly than in the previously described state. As a result of it, the seat is excessively stressed and may get worn. The valve becomes fully open when securing medium increases by max. 5% above the value of set opening pressure. (p_{set}). The valve becomes tight closed when securing medium pressure drops by max. 10% below the value of set opening pressure (p_{set}).

Accessories

Safety valves make an integral equipment together with their accessories consisting of the following:

- control unit type RP 5330
- remote signalisation of stroke value

Remote signalisation

Remote signalisation, fixed on the valve body, consists of micro switch and it serves to control the function of safety valve from a distant operating location where it signals "open" and "close" positions. Sensitivity of micro switch enables to register the plug stroke of 0,5 - 1 mm. Remote signalisation can operate in ambient temperature to 60 C. It is delivered on a special request but a cable is



Ordering

ČSN 13 3060, section 1, article 5 applies to a certain extent. According to customer's request, producer works out a design for placing the safety valves on securing equipment. Customer must submit all the necessary data. Design contains all the essentials for ordering. Every order is technically cleared and its conclusion is defined in a questionnaire to be confirmed binding by both parties.

Transport and storage

The safety valves including their accessories shall be transported in covered, dry and clean vehicles and other means of transport. They shall be secured against getting damaged by other transported goods. Valves are delivered wrapped separately in PE foil and provided with lathes. Pressure hoses are fixed to the valve body. Control units are wrapped separately in boxes together with their accessories.

The valves shall be stored in dry (max. air humidity of 75%), covered and closed areas with non-aggressive environment. It is recommended to keep the valves in original wrappings. After unwrapping, it is necessary to protect the valve body (spring, needle etc.) as well as control unit from bumping or another damage. Plastic

Assembly, maintenance and operation

Instructions for proper assembly of the safety valve into pipeline, its connection to control unit and principles for its operation and maintenance are specified in document PM 076. This document is delivered together with the valve.

Based on our long-time experience, we recommend to carry out inspection and checking of setting the opening pressure periodically once a year. A recommended period for overhaul inspection (checking the state of sealing surface of seat and plug, checking of piston sealing in air cylinder) is every 3 years.

Connection dimensions

DN	SS execution		SP execution		PP execution	
	S ₁	S ₂	S ₁	S ₂	S ₁	S ₂
	[mm]	[mm]	[mm]	[mm]	[mm]	[mm]
25x40	170	170	130	170	130	130
40x65	200	200	150	200	150	180
50x80	225	225	180	225	180	180
65x100	240	240	180	240	180	185
80x125	260	260	205	260	205	220
100x150	260	260	215	260	215	215
125x200	390	330	390	330	390	330
150x250	340	340	245	340	245	260
175x300	350	390	265	390	265	290
200x350	430	410	320	410	320	310
250x400	450	440	340	440	340	340
300x500	520	510	380	510	380	410
350x600	600	590	450	590	450	490

Detail of valve connection

SP execution

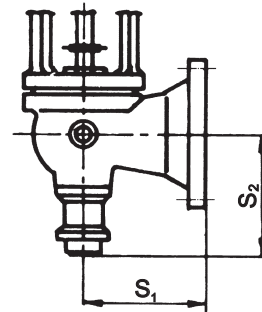

PP execution

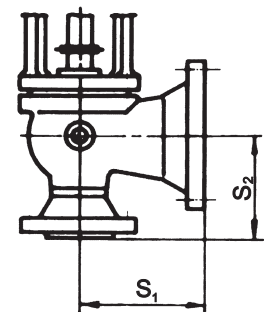

Drain-off piping connection dimensions

DN	A	B	ØC	b	Ød	s
	mm	mm	mm	mm	mm	mm
25x40	230	259	30	45	17.2	2.9
40x65	290	289	30	60	17.2	2.9
50x80	330	321	45	65	21.3	3.25
65x100	370	336	51	75	21.3	3.25
80x125	440	381	60	90	26.9	3.25
100x150	500	426	64	100	26.9	3.25
125x200	530	466	64	100	26.9	3.25
150x250	600	466	76	110	26.9	3.25
175x300	660	468	76	110	26.9	3.25
200x350	750	285	95	120	26.9	3.25
250x400	790	285	95	120	26.9	3.25
300x500	930	356.5	125	140	33.7	3.85
350x600	1140	367.5	135	150	33.7	3.85

Detail of drain-off piping connection

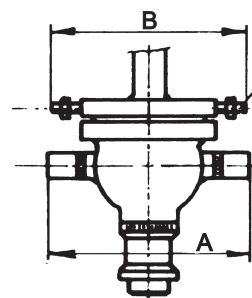
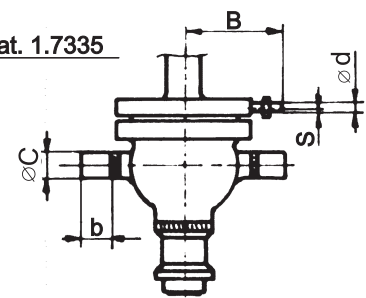
With two drain-offs
to DN 175 x 300With one drain-off
DN 200 x 350

Material of main parts

Název	Material			
	up to 400°C DN 100x150 - 350x600	up to 550°C DN 25x40 - 350x600	up to 575°C DN 25x40 - 350x600	up to 620°C DN 25x40 - 350x600
1 Body	1.0619 (A216WCB)	1.7357 (A217WC6)	1.7379 (A217 WC9)	1.4931
2 Insertion with seat + seat weld	1.0426 + Stelit 6 (A516+Stelit 6)	1.7335 + Stelit 6 (A182F12 (F11)+Stelit 6)	1.7380 + Stelit 6 (A182F22 +Stelit 6) 1.7383 + Stelit 6 (A182F22 +Stelit 6)	1.4901 + Stelit 6 (A182F92 +Stelit 6) 1.4903 + Stelit 6 (A182F91 +Stelit 6)
3 Plug + seat weld	1.4923 + Stelit 6 / 1.4922 + Stelit 6 (1.7335 + Stelit 6)			1.4901 + Stelit 6 1.4903 + Stelit 6
4 Plug guide	42 2942 / 1.4541			1.4923
5 Needle	17 027 / 1.4122			1.4903/1.4923
6 Main spring	50CrV4 / 51CrV4 / 52CrMoV4			
7 Cylinder liner	42 3119 / 42 2941 / 42 2906 / 1.4552 / 1.4581			
8 Yoke - lower bonnet	1.0619 / 1.0425	1.7357 / 1.7335	1.7379 / 1.7380	1.4931 / 1.4903
9 Dumping spring	50CrV4 / 51CrV4 / 52CrMoV4			
10 Yoke extension piece	1.0619			
11 Upper bonnet	1.0619			
12 Piston	1.0619			
13 Adjusting screw	17 021 / 1.4006			
14 Extension piece	1.0426 (A516)	1.7335 (A182F12 (F11))	1.7380 (A182F22) 1.7383 (A182F22)	1.4901 (A182F92) 1.4903 (A182F91)

Face to face lengths, dimensions, weights

DN	h ₁ [mm]	h ₂ [mm]	h ₃ [mm]	H [mm]	D [mm]	m [kg]
25x40	70	515	600	685	240	62
40x65	85	610	700	785	305	80
50x80	95	730	820	905	305	120
65x100	110	800	910	1010	335	180
80x125	125	720	835	1060	335	230
100x150	125	875	985	1090	335	240
125x200	160	990	1125	1245	450	430
150x250	165	1000	1135	1250	450	310
175x300	180	1045	1180	1310	450	400
200x350	210	1210	1385	1510	450	640
250x400	225	1240	1415	1545	450	750
300x500	270	1270	1470	1600	450	950
350x600	338	1295	1495	1620	450	1450

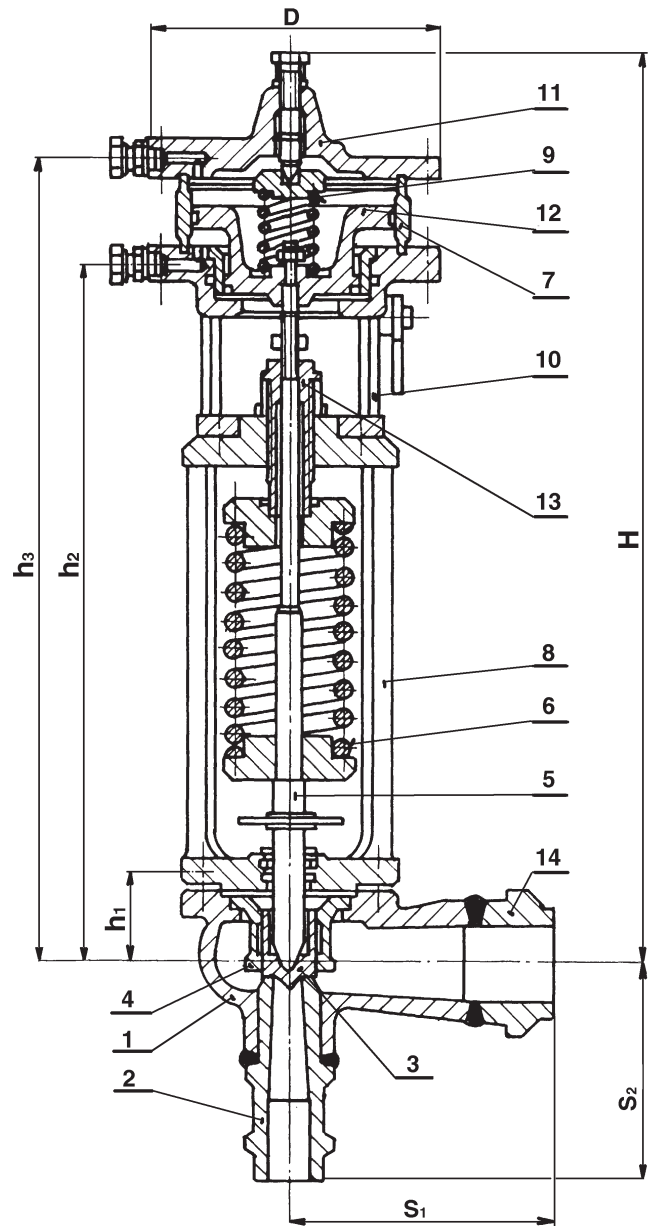

Valve complete specification No. for ordering SiZ 1508

		XX	XXXX	XXX	/	XXX	-	XXX	XX	/	X	-	XXX.X	/	X
		SiZ													
1. Valve	Safety valve														
2. Series			1508												
3. Nominal size DN	DN-inlet			065											
	DN-outlet					100									
	d-seat							046							
4. Connection	weld / weld								SS						
	weld / flange								SP						
	flange / flange								PP						
5. Body material	to 400°C													1	
	to 550°C													2	
	to 620°C													3	
	to 575°C													4	
	according to customer specification													9	
6. Opening pressure	barg												120.5		
7. Protected medium	saturated steam														1
	overhoted steam														2
	air														3
	other gasses														4

Order example: **SiZ 1508 065/100-046 PP/1-120,5/1**



LDM, spol. s r.o.
Litomyšlská 1378
560 02 Česká Třebová
Czech Republic

tel.: +420 465 502 511
fax: +420 465 533 101
e-mail: sale@ldm.cz

LDM, spol. s r.o.
Office Prague
Podolská 50
147 01 Praha 4
Czech Republic

tel.: +420 241 087 360
fax: +420 241 087 192
e-mail: sale@ldm.cz

LDM, spol. s r.o.
Office Ústí nad Labem
Ladova 2548/38
400 11 Ústí nad Labem
- Severní Terasa
Czech Republic

tel.: +420 602 708 257
e-mail: tomas.kriz@ldm.cz

LDM servis, spol. s r.o.
Litomyšlská 1378
560 02 Česká Třebová
Czech Republic

tel.: +420 465 502 411-3
fax: +420 465 531 010
e-mail: servis@ldm.cz

LDM Bratislava s.r.o.
Mierová 151
821 05 Bratislava
Slovakia

tel.: +421 2 43415027-8
fax: +421 2 43415029
e-mail: ldm@ldm.sk

LDM, Polska Sp. z o.o.
ul. Bednorza 1
40 384 Katowice
Poland

tel.: +48 32 730 56 33
fax: +48 32 730 52 33
mobile: +48 601 354 999
e-mail: ldmpolska@ldm.cz

LDM Armaturen GmbH
Wupperweg 21
D-51789 Lindlar
Germany

tel.: +49 2266 440333
fax: +49 2266 440372
mobile: +49 177 2960469
e-mail: ldmmarmaturen@ldmvalves.com

OOO "LDM Promarmatura"
Jubilejnyj prospekt,
dom.6a, of. 601
141400 Khimki Moscow Region
Russia

tel.: +7 4957772238
fax: +7 4956662212
mobile: +7 9032254333
e-mail: inforus@ldmvalves.com

TOO "LDM"
Shakirova 33/1
kab. 103
100012 Karaganda
Kazakhstan

tel.: +7 7212 566 936
fax: +7 7212 566 936
mobile: +7 701 738 36 79
e-mail: sale@ldm.kz

LDM - Bulgaria - OOD
z. k. Mladost 1
bl. 42, floor 12, app. 57
1784 Sofia
Bulgaria

tel.: +359 2 9746311
fax: +359 2 9746311
mobile: +359 888 925 766
e-mail: ldm.bg@ldmvalves.com

www.ldmvalves.com

LDM reserves the right to modify or improve the designs or specifications of such products at any time without notice.

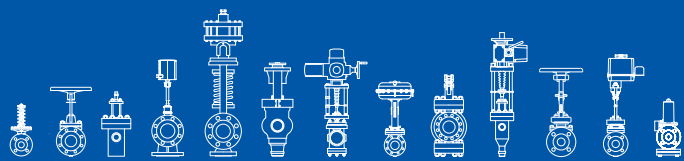
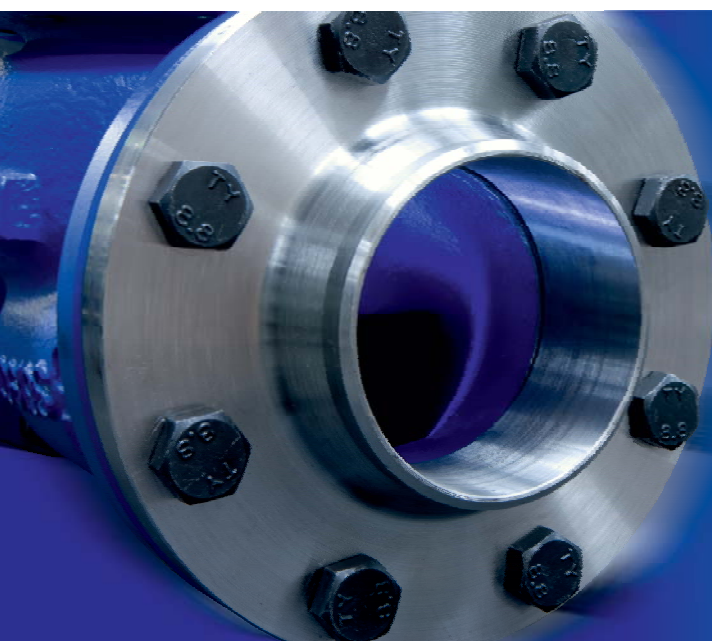

POWER THROUGH IDEAS