



02 - 07.2
03.23.GB

CONTROL UNIT **RP 5330**



Pneumatic control unit RP 5330 is designed for control of spring loaded safety valves with additional pneumatic loading (pneumatic actuator), type SiZ 1508 and PV 1509

manufactured by LDM Co. Ltd., Česká Třebová. Essential parts of control unit are mechanical which guarantees top-notch service reliability and precision in demanding working conditions.

RP 5330 unit also provides other important functions to the operator: for example option to set value of opening pressure of control unit during appliance shut-down or option to set opening pressure of safety valve by means of opening air pressure - lifting air pressure diagram (K-line), allowing to adjust safety valve with appliance pressure levels lower than set opening pressure.



Description

RP 5330 consist of robust steel frame to which are fastened all components. Frame is furnished with 4 threaded holes (M16) for anchoring to construction. Steel case serves only as a protection of components against mechanical damage, unqualified person operation and environment conditions (dust, humidity,...). Shelter providing rain protection is needed in the case of outdoor installation.

There are three tapping line connections in the bottom side of the unit (tube 33,7x5 / (32x6), material 1.7335 / 1.7380 / 1.5415 / 1.4903 / (1.0577). These tapping lines connects control unit to from one to three pressure tapping points with possibly different pressure levels.

At the top side of control unit, connection of supply pressure air (M22x1.5 male thread), connector / cable for solenoid valve control (230V/50Hz) and two connections for lifting air and two for loading air (M27x1.5 male thread) are placed.

In the case that control unit is in charge of only one safety valve, there is only one lifting air and one loading air connection.

Pressure air supply to control unit has to be permanent. Installation of solenoid valve control cable enables manual remote control by the maintenance crew or by plant automatic control system. Loading and lifting pressure connections are piped to pneumatic cylinder of safety valve.

Maximum environment temperature is 60°C. For sub-zero temperatures alternative version with supplementary heating can be supplied after agreement with manufacturer.

Control unit is adjusted to set opening pressure specified in the order and tested in factory. Adjustment elements are secured against unwarranted interference.

Control unit weights approximately 80 kg.

Operation

Control unit operates connected safety valves by controlling pressure of lifting and loading air. Before reaching set opening pressure, loading pressure increases closing force on plug which leads to better tightness and longevity of valve. When set opening pressure is reached, control unit releases loading pressure air. Lifting pressure air then induces nearly instantaneous opening to full stroke. Upon pressure drop below set opening pressure control unit again applies loading pressure air. That again provides fast and tight closure of safety valve.

Pressure air necessary for operation of control unit is delivered by pressure air line (12) through shut-off valve (13), air filter (14) and main pressure reduction valve (15). Pressure is reduced to 0,4 Mpa.

Loading pressure air tubing (37) supplies pressure air above pneumatic piston (3) of safety valve. Control pressure air is reduced via pressure reduction valve (17) to 60 kPa and then delivered to jet nozzles (21). As long as control flags (11) of Bourdon tubes (10) do not obstruct flow of pressure air to chamber behind jet nozzles, air pressure is distributed to three diaphragm valves (22) and keeps them closed. (This diaphragm valves would release loading pressure air when opened.) Loading pressure air enters through throttling orifice (23) into loading pressure tubing (38) with max pressure reaching 0.4 MPa (i.e. the same as lifting air). Effective area of differential pneumatic piston (3) in loading direction is twice as large as in lifting direction. Therefore in normal state it imposes additional loading force on the valve plug (2).

When the pressure in protected appliance rises above opening pressure set on control unit, Bourdon tubes (10) are deformed and their control flags (11) block air flow from jet nozzles (21). Control air interruption causes pressure loss upon diaphragm valves (22). These diaphragm valves open and release loading air pressure from the top of the safety valve piston to the atmosphere. As a result, safety valves (2) open to full stroke in a very short time - lifting pressure now acts on the lower side of the piston (3) of safety valve unopposed which increases opening force on the plug.

Opening of the safety valves (2) causes pressure drop in the protected device (1). Subsequently Bourdon tubes (10) move in the opposite direction and control flags (11) clear the chamber adjacent to nozzle jets (21). Control air pressure upon diaphragm valves is restored which inflicts closure of diaphragm valves (22). Loading air pressure above the piston (3) of safety valves is restored which causes rapid and safe closure of safety valves (2).

Requirements for air quality

Pressure air quality must meet ISO 8573-1 requirements :

- Class of solid particles 4 or better
(i.e. particle max. size 15 µm, concentration max. 8 mg/m³)
- Class of water 4 or better
(i.e. condensation point max. +3°C)
- Class of oil 3 or better (i.e. concentration max 1 mg/m³)

Design of control unit according to ambient temperature

RP 5330 standard design (without insulation and internal heating)

- for operation in ambient temperature range +5°C to +60°C

RP 5330 with internal insulation and internal heating

- for operation in ambient temperature range -30°C to +60°C,

- insulation glued on the inside of the unit, heating provided by heating elements (heating power of the elements according to the selected ambient temperature) controlled by thermostat

RP 5330 with external insulation jacket and internal heating

- for operation in ambient temperature range -60°C to +60°C

- insulation jacket placed on the unit, heating provided by heating plates with a power of 2 x 200 W controlled by a thermostat

Functional chart of control unit

HP zone:

1. Protected appliance
2. Safety valve (SV)
3. Pneumatic cylinder piston
4. Blow-off piping
5. Drain pipe
6. Pressure tapping line
7. Three way shut-off valve
8. Tapping line pressure gauge
9. Connection of independent pressure source
10. Bourdon tubes
11. Control flag

LP zone:

12. Pressure air line
13. Shut-off valve
14. Air filter
15. Main pressure reduction valve (0.6 - 0.4 MPa)
16. Operating air pressure gauge
17. Control air reduction valve (0.4 - 0.06 MPa)
18. Control air pressure gauge
19. Solenoid valve
20. Shut-off valve
21. Jet nozzle
22. Diaphragm valve
23. Loading air throttling orifice
24. Lifting air throttling orifice
25. Three way shut-off valve of loading air - 1st safety valve
26. Three way shut-off valve of loading air - 2nd safety valve
27. Loading air outlet - 1st safety valve
28. Loading air outlet - 2nd safety valve
29. Loading air pressure gauge - 1st safety valve
30. Loading air pressure gauge - 2nd safety valve
31. Three way shut-off valve of lifting air - 1st safety valve
32. Three way shut-off valve of lifting air - 2nd safety valve
33. Lifting air pressure gauge - 1st safety valve
34. Lifting air pressure gauge - 2nd safety valve
35. Lifting air external source connection - 1st safety valve
36. Lifting air external source connection - 2nd safety valve
37. Lifting air tubing
38. Loading air tubing
39. Shut-off control valve (K-line)

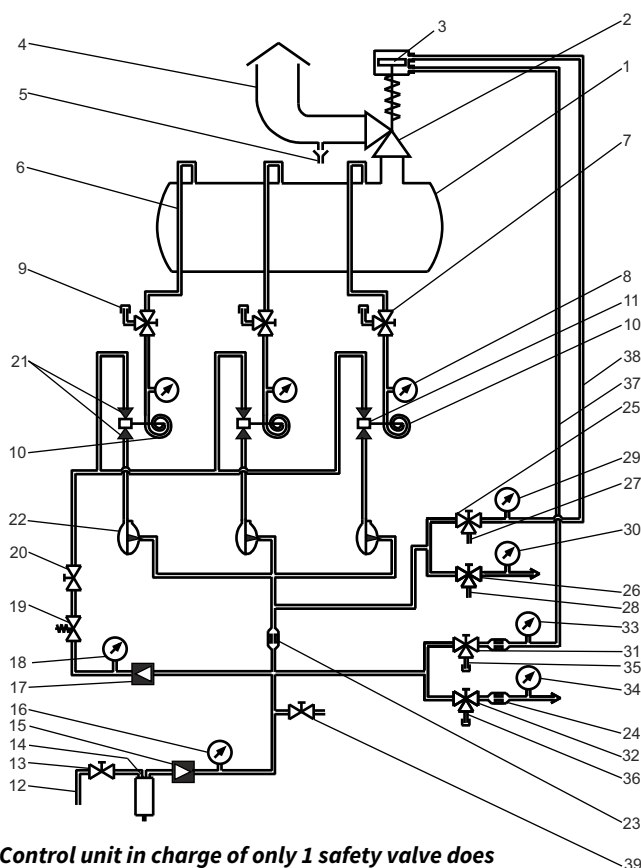

Control unit in charge of only 1 safety valve does not contain these positions: 26, 28, 30, 32, 34, 36 a D, E, L, M.

Connection dimensions

Design for ambient temperature till +5°C, -20 °C, -30 °C
weight 80 kg

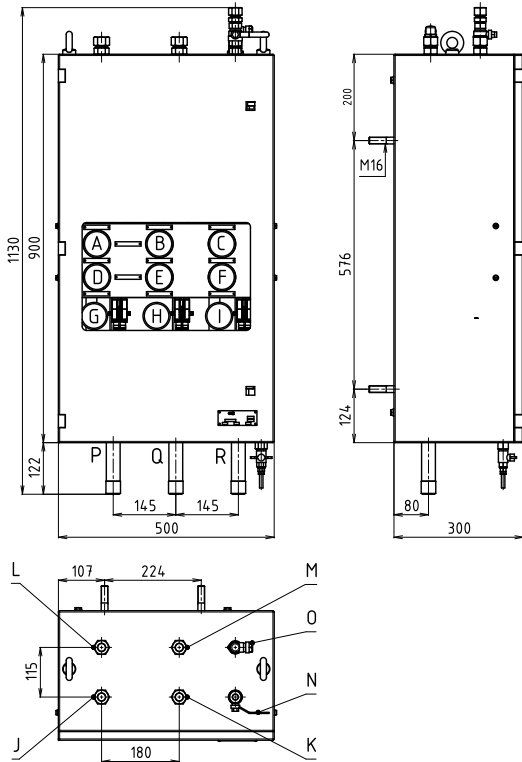

- A** Lifting air pressure gauge - 1st safety valve
- B** Loading air pressure gauge - 1st safety valve
- C** Operating air pressure gauge
- D** Lifting air pressure gauge - 2nd safety valve
- E** Loading air pressure gauge - 2nd safety valve
- F** Control air pressure gauge
- G** 1st tapping line pressure gauge
- H** 2nd tapping line pressure gauge
- I** 3rd tapping line pressure gauge

Design for ambient temperature till -60 °C
weight 90 kg

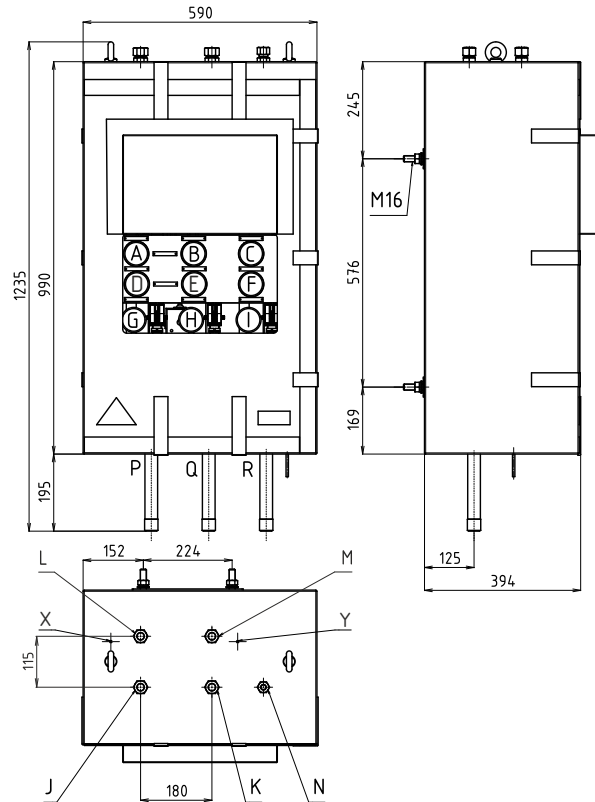

- J,K** Lifting / loading air connection to 1st safety valve (thread M27x1.5)
- L,M** Lifting / loading air connection to 2nd safety valve (thread M27x1.5)
- N** Control air shut-off valve (thread M22x1.5)
- O** Remote control connection
- P,Q,R** Tapping lines connection
- X** Inner heating connection 230V / 50 Hz AC
- Y** Remote control connection - cable 230V / 50 Hz AC

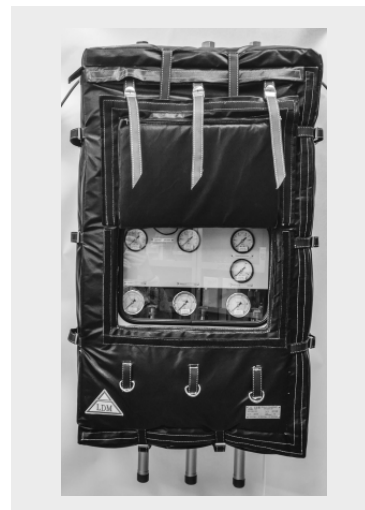

Sestavení typového čísla RP 5330

		XX	XXXX	/	X	X	/	X	XX
1. Control unit		RP							
2. Type of control unit			5330						
3. Number of connected SV					1				
					2				
4. Control type	Remote							0	
	Remote + outer							1	
5. Heating	without								0
	max. -20 °C *)								2
	max. -30 °C *)								3
	max. -60 °C **)								6
	custom version								9
6. Version	N1 (for 1 SV - lifting and loading pressure air is piped into SV piston)								N1
	T1 (for 1 SV - loading pressure air alone is piped into SV piston)								T1
	N2 (for 2 SV - lifting and loading pressure air is piped into both safety valves)								N2
	T2 (for 2 PV - loading pressure air alone is piped into both safety valves)								T2
	NT (for 2 SV - lifting and loading pressure air is piped into piston of 1st safety valve™, loading pressure air alone is piped into piston of 2nd safety valve)								NT
	TN (for 2 SV - loading pressure air alone is piped into piston of 1st safety valve™, lifting and loading pressure air is piped into piston of 2nd safety valve)								TN

Notes:

*) with internal insulation of unit

***) with outer insulation jacket



LDM, spol. s r.o.
Litomyšlská 1378
560 02 Česká Třebová
Czech Republic

tel.: +420 465 502 511
fax: +420 465 533 101
e-mail: sale@ldm.cz

LDM, spol. s r.o.
Office Prague
Podolská 50
147 01 Praha 4
Czech Republic

tel.: +420 241 087 360
fax: +420 241 087 192
e-mail: sale@ldm.cz

LDM, spol. s r.o.
Office Ústí nad Labem
Ladova 2548/38
400 11 Ústí nad Labem
- Severní Terasa
Czech Republic

tel.: +420 602 708 257
e-mail: sale@ldm.cz

LDM servis, spol. s r.o.
Litomyšlská 1378
560 02 Česká Třebová
Czech Republic

tel.: +420 465 502 411-3
fax: +420 465 531 010
e-mail: servis@ldm.cz

LDM Bratislava s.r.o.
Mierová 151
821 05 Bratislava
Slovakia

tel.: +421 2 43415027-8
fax: +421 2 43415029
e-mail: ldm@ldm.sk

LDM, Polska Sp. z o.o.
ul. Bednorza 1
40 384 Katowice
Poland

tel.: +48 32 730 56 33
fax: +48 32 730 52 33
mobile: +48 601 354 999
e-mail: ldmpolska@ldm.cz

LDM Armaturen GmbH
Wupperweg 21
D-51789 Lindlar
Germany

tel.: +49 2266 440333
fax: +49 2266 440372
mobile: +49 177 2960469
e-mail: ldmmarmaturen@ldmvalves.com

OOO "LDM Promarmatura"
Jubilejnyj prospekt,
dom.6a, of. 601
141400 Khimki Moscow Region
Russia

tel.: +7 4957772238
fax: +7 4956662212
mobile: +7 9032254333
e-mail: inforus@ldmvalves.com

TOO "LDM"
Shakirova 33/1
kab. 103
100012 Karaganda
Kazakhstan

tel.: +7 7212 566 936
fax: +7 7212 566 936
mobile: +7 701 738 36 79
e-mail: sale@ldm.kz

LDM - Bulgaria - OOD
z. k. Mladost 1
bl. 42, floor 12, app. 57
1784 Sofia
Bulgaria

tel.: +359 2 9746311
fax: +359 2 9746311
mobile: +359 888 925 766
e-mail: ldm.bg@ldmvalves.com

www.ldmvalves.com

LDM reserves the right to modify or improve the designs or specifications of such products at any time without notice.

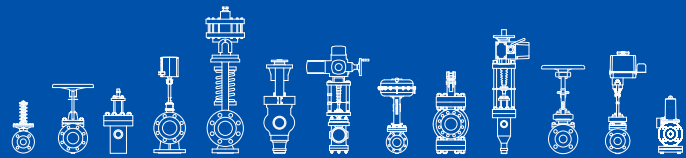
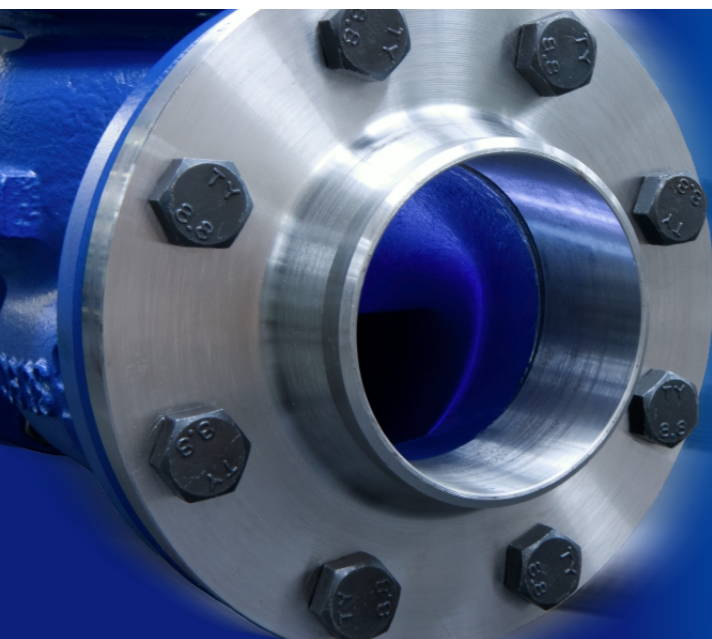

POWER THROUGH IDEAS